

## THERMAL CONTACT RESISTANCE BETWEEN MERCURY AND A METAL SURFACE

T. MIZUSHINA, S. IUCHI, T. SASANO and H. TAMURA\*  
Department of Chemical Engineering, Kyoto University, Kyoto, Japan

(Received 18 September 1959; revised 19 February 1960)

**Abstract**—This paper reports an experimental analysis of the contact resistance in heat transfer between stagnant mercury and a solid metal surface. It is shown experimentally that there is a very small amount of contact resistance between chromium-plated copper and pure mercury.

**Résumé**—Cet article décrit une étude expérimentale de la résistance de contact dans la transmission de chaleur entre du mercure au repos et une surface solide métallique. On montre expérimentalement que la résistance de contact entre cuivre chromé et mercure pur est très faible.

**Zusammenfassung**—Diese Arbeit behandelt eine experimentelle Untersuchung des thermischen Kontaktwiderstandes zwischen ruhendem Quecksilber und einer festen Metalloberfläche. Es zeigt sich aus den Versuchen, dass ein besonders kleiner Kontaktwiderstand zwischen chromplattiertem Kupfer und reinem Quecksilber besteht.

**Abstract**—В настоящей статье приводятся экспериментальные данные по сопротивлению между инертной ртутью и твердой металлической поверхностью в процессе теплообмена. На основании опытных данных показывается, что термическое сопротивление между пластиной из хромовой меди и чистой ртутью мало.

### NOTATION

- $A$  = cross-sectional area ( $m^2$ );  
 $A_{Hg}$  = equivalent cross-sectional area of mercury mass defined by equation (2) ( $m^2$ );  
 $h$  = heat-transfer coefficient ( $kcal/m^2 hr ^\circ C$ );  
 $J_0, J_1$  = Bessel functions of the first kind and zero- and first-order, respectively;  
 $k$  = thermal conductivity ( $kcal/m hr ^\circ C$ );  
 $q$  = heat transferred per unit time ( $kcal/hr$ );  
 $r$  = radial distance from axis ( $m$ );  
 $r_1$  = radius of copper cylinder ( $m$ );  
 $r_2$  = inner radius of Dewar vessel ( $m$ );  
 $t$  = temperature ( $^\circ C$ );  
 $\Delta x$  = clearance between solid surfaces ( $m$ );  
 $x$  = vertical distance ( $m$ );  
 $\lambda$  = variable in Bessel function;  
 $Nu$  = Nusselt number;  
 $Pe$  = Peclet number.

### Subscripts

- $c$  = contact surface;  
 $Hg$  = mercury;  
 $w$  = difference between two solid walls.

### INTRODUCTION

IN RECENT years, great interest in the use of liquid metal as a heat-transfer medium has been stimulated. Martinelli [1] developed the analogy between heat and momentum transfer in the case of liquid-metal heat transfer, and derived a complicated theoretical equation. This equation was simplified by Lyon [2] as follows:

$$Nu = 7.0 + 0.025 Pe^{0.8} \quad (1)$$

On the other hand, various investigators have accumulated experimental data, most of which unfortunately do not agree with Lyon's equation and are 30-40 per cent lower than the values predicted by the equation. Considerable numbers of experimental and theoretical investigations have been done in order to give explanations of this discrepancy.

\* Present address: Showa Denko Co. Ltd., Kawasaki, Japan.

Most of these investigations can be classified as follows:

(a) Thermal contact resistance between liquid metal and a solid surface (experimental study). These are completely covered by MacDonald and Quittenton [3].

(b) Gas entrainment phenomenon (experimental study). This was discussed by MacDonald and Quittenton [3] and Chelemer [4].

(c) Direct measurement of eddy-diffusivity ratio (experimental study). Isakoff and Drew [5], Brown *et al.* [6] and Mizushina *et al.* [7] studied this subject.

(d) Modification of momentum transfer analogy, assuming special models in heat-transfer mechanism (theoretical study). Deissler [8] and Lykoudis [9] developed different theories, respectively.

(e) Vorticity-transfer theory (theoretical study). Cope [10] discussed this subject.

As mentioned above there might be many reasons for this discrepancy, among which, however, only the thermal contact resistance between liquid metal and a solid metal will be studied experimentally in this paper. Mercury purified chemically was used as a liquid metal. Chromium-plated copper, pure copper and nickel plate were used as solid metal surfaces.

#### EXPERIMENTAL APPARATUS AND PROCEDURE

The experimental apparatus is shown schematically in Fig. 1. *A* and *B* are copper cylinders 20.5 cm long and 3.7 cm in diameter. The two end surfaces of *A* and *B* were polished on a surface plate to make them as flat as possible and then all surfaces were carefully plated with chromium. The thickness of the chromium deposit is less than  $\frac{1}{100}$  mm. In order to measure temperature distributions in the cylinders, fourteen copper-constantan thermocouples were inserted in radial direction and fixed on the centre line of the cylinders. Thus, 1.85 cm from the hot junction of each thermocouple lead is left in an isothermal region. Furthermore each thermocouple lead is wound twice around the cylinders. A melamine resin coating protects them from corrosion by mercury. The axial locations of the thermocouples are shown in Fig. 2. After the thermo-

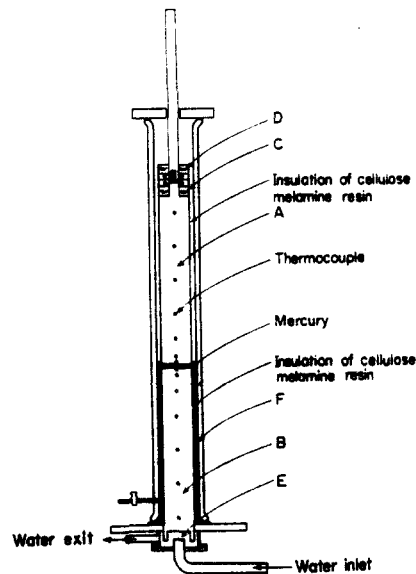

FIG. 1. Experimental apparatus.

couples were fixed in the cylinders, the whole cylinders were put in a  $0.01^{\circ}\text{C}$  thermostatted bath and the thermocouples were calibrated. *C* is an electric heater to supply heat to the upper end of *A*, and *E* is a water jacket to subtract heat from the lower end of *B*. *D* is an electric heater which serves as compensation for the heat loss from the main heater *C*. The cylindrical surfaces are doubly insulated thermally with cellulose-melamine resin coating and a Dewar vessel *F*. The clearance between *A* and *B* can be freely varied with a screw at the top of cylinder *A* and measured accurately to  $\frac{1}{25}$  mm by a cathetometer. The parallelness of the two surfaces was ascertained by measuring the clearance between the surfaces at three different points in every run. End surfaces of cylinders *A* and *B* being in contact with mercury, were carefully cleaned physically with benzene or ethyl alcohol before each experimental run. The space between *A* and *B* was filled up carefully with 99.999 per cent pure mercury. Not even a small bubble of gas was allowed to remain in the space. In some series of runs, a copper plate or a nickel plate was inserted in the middle of mercury layer between *A* and *B* at the beginning of runs. In such cases, the plate was supported in

a suitable distance with the needles fixed at the lower end of *A*. Since the thermal insulation was nearly complete, the full amount of the heat supplied to the upper end penetrates the whole system downwards without appreciable loss. This was confirmed by uniformity of the axial temperature gradient in the copper cylinders. The amount of the heat was measured as electric power to heater *C* with a voltmeter and an ammeter. The temperature distribution in the cylinder at the axis of cylinder was measured by

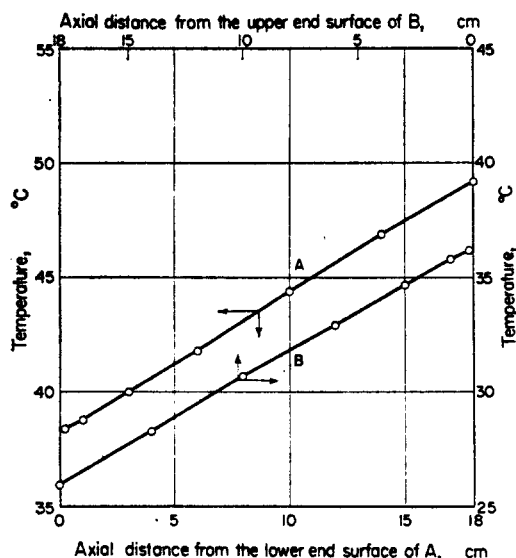

FIG. 2. A typical measurement of the axial temperature distribution in the copper cylinders *A* and *B*.

thermocouples and a potentiometer to 0.01°C. A typical measurement of the axial temperature is shown in Fig. 2.\*

Every measured value was recorded after the steady state was reached. The end-surface temperatures of *A* and *B* were obtained by extrapolation. After each run, the clearance between *A* and *B* was measured as fast as possible to prevent the effect of thermal expansion or contraction of the cylinders.

\* It may be interesting to compute, as a check, the thermal conductivity of the copper from this measurement. The value obtained was 274 kcal/m hr °C, which is lower than 330 kcal/m hr °C of the generally used value. The greatest cause of this discrepancy might be an impurity in the copper.

### ANALYSIS

Suppose that there is something like a boundary layer having resistance to heat transfer between the stagnant mercury and the solid metal. The layer could be an absorbed gas layer

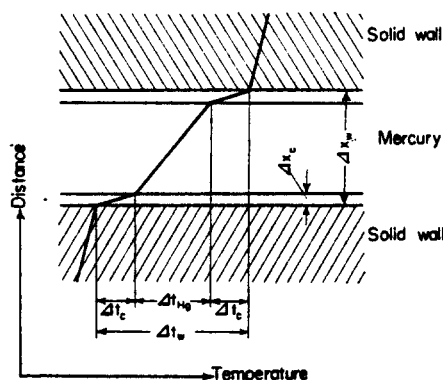

FIG. 3. A schematic representation of the temperature profile in the vicinity of the contact interface.

or a metallic oxide film or any other contaminant. At steady state, the following equations are given (see Fig. 3):

In mercury

$$q = A_{\text{Hg}} \cdot k_{\text{Hg}} \cdot (\Delta t / \Delta x)_{\text{Hg}} \quad (2)$$

In boundary layer

$$q = A_c \cdot h_c \cdot (\Delta t)_c \quad (3)$$

and

$$(\Delta t)_{\text{Hg}} = (\Delta t)_w - 2(\Delta t)_c \quad (4)$$

From equations (2), (3) and (4)

$$\frac{(\Delta t)_w}{q} = \frac{(\Delta x)}{A_{\text{Hg}} \cdot k_{\text{Hg}}} + \frac{2}{A_c \cdot h_c} \quad (5)$$

Since the thickness of the boundary layer  $(\Delta x)_c$  is very small,

$$(\Delta x)_{\text{Hg}} = (\Delta x)_w - 2(\Delta x)_c \doteq (\Delta x)_w \quad (6)$$

As shown in Fig. 1, the cylindrical mass of mercury has a cross-sectional area larger than those of the copper cylinders. The former is  $1.37 \times 10^{-3} \text{ m}^2$  and the latter is  $1.075 \times 10^{-3} \text{ m}^2$ . Thus, the heat flux curves slightly outwards in the mercury layer. Therefore,  $A_{\text{Hg}}$  in equation (2) should be an equivalent cross-sectional area

consistent with the representation of equation (2) and thus is affected by the geometrical condition. By solving a heat conduction problem,  $A_{Hg}$  for this case was given as

$$A_{Hg} = 1.075 \times 10^{-3} (1 + 24.8 \Delta x_{Hg}) \quad (7)$$

where  $A_{Hg}$  and  $\Delta x_{Hg}$  are in square metres and metres, respectively. The calculations are shown in appendix. Hence, if the values of  $(\Delta t)_w$ ,  $q$  and  $(\Delta x)_w$  or  $(\Delta x)_{Hg}$ , are measured, one can obtain the values of  $h_c$  and  $k_{Hg}$  by a graphical method. When the value of  $(\Delta t)_w/q$  are plotted against  $(\Delta x)_{Hg}/A_{Hg}$ , the intercept at  $(\Delta x)_{Hg}/A_{Hg} = 0$  gives  $2/(A_c h_c)$  and the gradient  $d(\Delta t)_w/q/d(\Delta x)_{Hg}/A_{Hg}$  gives  $1/k_{Hg}$ .

When a thin metal plate is inserted in the mercury layer parallel to the metal surfaces, two contact surfaces are added. Denote the contact area of the inserted plate  $A_c'$ , and its contact heat transfer coefficient  $h_c'$ , thus

$$\frac{\Delta t_w}{q} = \frac{(\Delta x)}{A_{Hg} \cdot k_{Hg}} + \frac{3}{A_c h_c} + \frac{2}{A_c' h_c'} + \frac{(\Delta x)_{plate}}{A_c' \cdot k_{plate}} \quad (8)$$

In this case the intercept at  $(\Delta x)_{Hg}/A_{Hg} = 0$  gives  $[2/(A_c h_c) + 2/A_c' h_c' + (\Delta x)_{plate}/(A_c' \cdot k_{plate})]$ . As the last term can be calculated and the first term is determined by the experiment without inserting a plate, one can determine the resistance  $2/(A_c' h_c')$  between the mercury and the inserted plate.

## RESULTS AND DISCUSSIONS

The plots in Fig. 4 show the experimental data of thermal contact resistance between pure mercury and chromium-plated copper as well as the case with a copper plate inserted. However, only the data of the former case was correlated, since the data of the latter scattered considerably.

### 1. The contact resistance between chromium-plated copper and pure mercury and the thermal conductivity of mercury

A least-squares line was put through the data as shown in Fig. 4. From the magnitude of the intercept and gradient, two unknown values of  $2/(A_c h_c)$  and  $k_{Hg}$  in the equation (5) were

computed as  $2/(A_c h_c) = 0.009$  hr °C/kcal and  $k_{Hg} = 8.46$  kcal/m hr °C.

Since  $A_c = \pi r_1^2 = 1.075 \times 10^{-3}$  m<sup>2</sup>, the thermal contact resistance  $1/h_c = 0.48 \times 10^{-5}$  m<sup>2</sup> hr °C/kcal.

### 2. Runs in which a copper plate is inserted

In order to examine the thermal resistance between copper and mercury, the runs in which a copper plate is inserted were also performed. The experimental results are plotted in Fig. 4. In this case the last term in equation (8)

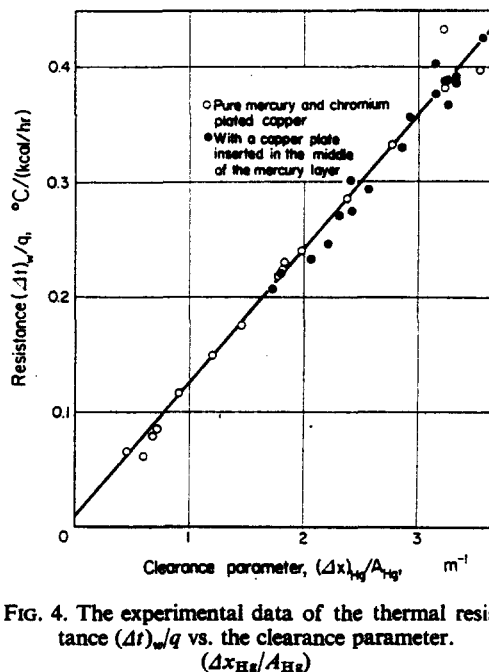

FIG. 4. The experimental data of the thermal resistance  $(\Delta t)_w/q$  vs. the clearance parameter  $(\Delta x)_{Hg}/A_{Hg}$ .

is negligible, since the thickness of the plate is very small (about 0.1 mm) and the thermal conductivity of the copper is much larger than that of mercury. If a correlating line is obtained, the intercept would correspond to twice the resistance between chromium-plated copper and mercury plus twice the resistance between copper plate and mercury. However, the data of these runs are not so different from the case of no copper plate insertion, but the former are slightly lower than the latter in thermal resistance  $(\Delta t)_w/q$ . It may, therefore, be said that there is no thermal contact resistance between copper plate and

mercury and even that the decrease of the contact resistance between mercury and chromium-plated copper occurs owing to the wetting effect by copper slightly dissolved in mercury.

### 3. Other series of runs

In addition to the data plotted in Fig. 4, several other series of runs were performed. Without the insertion of a plate, two other series of runs were performed and the following results were obtained, respectively:

$$1/h_c = 2.15 \times 10^{-5} \text{ m}^2 \text{ hr } ^\circ\text{C}/\text{kcal},$$

$$k_{\text{Hg}} = 8.8 \text{ kcal}/\text{m hr } ^\circ\text{C}$$

$$1/h_c = 1.88 \times 10^{-5} \text{ m}^2 \text{ hr } ^\circ\text{C}/\text{kcal},$$

$$k_{\text{Hg}} = 8.25 \text{ kcal}/\text{m hr } ^\circ\text{C}$$

In another run, a thin nickel plate was inserted in the mercury layer. The increase of thermal contact resistance  $2/(A_c' h_c')$  was 0.024 hr  $^\circ\text{C}/\text{kcal}$ . Since

$$A_c' = 1.35 \times 10^{-3} \text{ m}^2,$$

$$1/h_c' = 1.62 \times 10^{-5} \text{ m}^2 \text{ hr } ^\circ\text{C}/\text{kcal}.$$

A nickel surface seems not to differ from a chromium surface in its character so far as the behaviour of contact with mercury is concerned. If the thermal resistance between the copper base and the plated chromium film is appreciable, the contact resistance between mercury and the chromium-plated copper should be larger than that between mercury and the nickel plate. Since this is not the case, it may support the assumption that there is no thermal resistance between the copper base and the plated chromium film.

Thus, the magnitude of the thermal contact resistance  $1/h_c$  between pure mercury and a chromium or nickel surface, is in the range of 0.48 to  $2.15 \times 10^{-5} \text{ m}^2 \text{ hr } ^\circ\text{C}/\text{kcal}$ .

Now the effects of various probable errors on the value obtained for the thermal contact resistance will be discussed.

(1) Since the accuracy in measuring the clearance between the surfaces is about  $\frac{1}{30}$  mm, the resulting error in the value of the interfacial resistance can be as high as

$$(\frac{1}{30} \times 10^{-3})/7.9 = 0.6 \times 10^{-5} \text{ m}^2 \text{ hr } ^\circ\text{C}/\text{kcal}.$$

However, as the probabilities of overestimation and underestimation can be assumed to be equal, a least-squares procedure may decrease the error.

(2) It is difficult to determine the positions of the thermocouple junctions accurately. However, the thermocouple holes were drilled carefully and the error in determining the position of the junction might be about 0.2 mm, which corresponds to an error of

$$0.7 \times 10^{-6} \text{ m}^2 \text{ hr } ^\circ\text{C}/\text{kcal}$$

for the contact resistance.

(3) As the thickness of the chromium deposit is less than  $\frac{1}{100}$  mm, its thermal resistance is substantially negligible.

(4) If a part of the heat supplied to the upper end of the cylinder was lost out of the system, one should estimate the magnitude of  $\Delta t/q$  slightly larger, and so also the value of the contact resistance. However, since the temperature gradient in the copper cylinders was substantially uniform, this effect may be small.

(5) As the thermal contraction of the copper cylinder during the measurement of the clearance is inevitable, one might possibly overestimate the clearance. If the temperature descent of the copper cylinder during the measurement was  $1^\circ\text{C}$ , the contraction of a copper cylinder of 20 cm could reach 0.003 mm, which results in an error of  $0.4 \times 10^{-6} \text{ m}^2 \text{ hr } ^\circ\text{C}/\text{kcal}$  in estimating the contact resistance.

Consequently, the possible magnitude of accumulated errors in the contact resistance may be between  $10^{-6}$  and  $10^{-5} \text{ m}^2 \text{ hr } ^\circ\text{C}/\text{kcal}$ . Therefore, it may be concluded that there is a thermal contact resistance between a chromium-plated copper surface and pure mercury a few times  $10^{-5} \text{ m}^2 \text{ hr } ^\circ\text{C}/\text{kcal}$  at most.

The heat transfer coefficient of mercury flow inside a round tube of 2 cm inside diameter at Peclet number = 1000 can be calculated by Lyon's equation (1) as  $h = 5000 \text{ kcal}/\text{m}^2 \text{ hr } ^\circ\text{C}$ . If the value of the contact resistance between mercury and metal wall is assumed to be  $1 \times 10^{-5} \text{ m}^2 \text{ hr } ^\circ\text{C}/\text{kcal}$ , the value of the heat transfer coefficient will decrease to  $4750 \text{ kcal}/\text{m}^2 \text{ hr } ^\circ\text{C}$ . On the other hand, the experimental heat transfer coefficient at the same condition is about  $3900 \text{ kcal}/\text{m}^2 \text{ hr } ^\circ\text{C}$ . Therefore, the

thermal contact resistance plays only a part of the role in the discrepancy between theoretical prediction and the experimental data of heat-transfer.

Average temperature of the mercury layer was about 40°C and the value of  $k_{\text{Hg}}$  at this temperature is given as 7.9 kcal/m hr °C by the *Liquid Metals Handbook* [11], while Gehlhoff and Neumeier [12] gives 10 kcal/m hr °C at the same temperature. Experimental values of the present work are in the range of from 8.25 to 8.8 kcal/m hr °C, which is slightly larger than the data of *Liquid Metals Handbook*. This may partly be due to the small amount of heat loss out of the system from the upper cylinder and partly due to the heat transferred between the mercury and the cylindrical wall of the cylinders. If the former is taken into account, the estimated  $q$  must decrease and  $\Delta t/q$  must increase and consequently  $k_{\text{Hg}}$  must decrease, while the latter makes the apparent magnitude of  $A_{\text{Hg}}$  somewhat larger and thus the value of  $k_{\text{Hg}}$  smaller.

#### CONCLUSION

There is a small amount of thermal contact resistance of the order of  $10^{-5}$  m<sup>2</sup> hr °C/kcal but less than a few times of that between a chromium-plated surface and pure liquid mercury. Its magnitude is, however, not so large as to explain the whole amount of discrepancy between the theoretical prediction and the experimental data of heat transfer.

#### ACKNOWLEDGEMENTS

The writers wish to express their thanks to the Ministry of Education of Japan, and Asahi Glass Co. Ltd. for their Financial support, and to acknowledge gratefully the valuable contributions of T. Tsujino and H. Kamimura in the construction of the apparatus and the preliminary work.

#### REFERENCES

1. R. C. MARTINELLI, *Trans. Amer. Soc. Mech. Engrs.* **69**, 947 (1947).
2. R. N. LYON, *Chem. Engng. Progr.* **47**, 75 (1951).
3. W. C. MACDONALD and R. C. QUITTENTON, *Chem. Engng. Progr. Symposium Series 50*, No. 9, 59 (1954).
4. H. CHELEMER, Ph.D. Thesis, University of Tennessee (1955).
5. S. E. ISAKOFF and T. B. DREW, *General Discussion on Heat Transfer* p. 405. Institution of Mechanical Engineers, London (1951).
6. H. E. BROWN, B. H. AMSTEAD and B. E. SHORT, *Trans. Amer. Soc. Mech. Engrs.* **79**, 279 (1957).

7. T. MIZUSHINA, S. IUCHI, M. NAKAO and T. SASANO' Unpublished.
8. R. G. DESSLER, NACA RM E52F05 1 (1952).
9. P. S. LYKOUSIS, Ph.D. Thesis, Purdue University (1956).
10. W. F. COPE, *General Discussion on Heat Transfer* p. 453. Institution of Mechanical Engineers, London (1951).
11. R. LYON (Editor), *Liquid Metals Handbook* (2nd Ed.) p. 43. Atomic Energy Commission, Washington, D.C. (1952).
12. G. GEHLHOFF and F. NEUMEIER, *Verh. d. Phys. Ges.* **21**, 201 (1919).

#### APPENDIX

##### Mathematical Estimation of $A_{\text{Hg}}$

As represented schematically in Fig. 5 the complicated heat flow in the mercury layer can be analysed as a problem of the steady-state heat conduction in a cylinder which has the following boundary conditions:

$$\begin{aligned} x = \Delta x & & r \leq r_1 & & t = t_0 \\ x = 0 & & r \leq r_1 & & t = 0 \end{aligned} \quad (9)$$

$$\begin{aligned} x = \Delta x & & r_2 \geq r > r_1 & & \partial t / \partial x = 0 \\ x = 0 & & r_2 \geq r > r_1 & & \partial t / \partial x = 0 \end{aligned} \quad (10)$$

$$r = r_2 \quad \Delta x \geq x \geq 0 \quad \partial t / \partial r = 0 \quad (11)$$

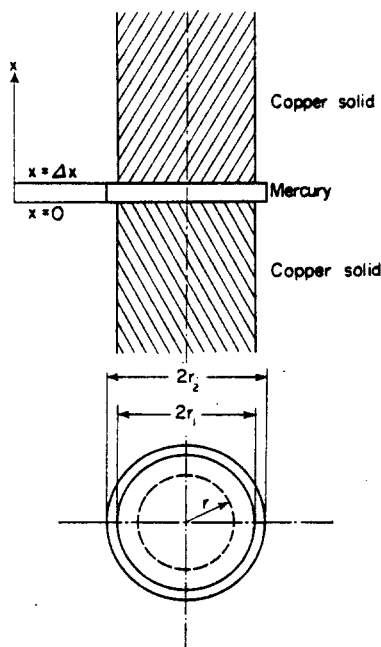

FIG. 5. A simplified model of heat conduction occurred in the experimental apparatus.

The equivalent cross-sectional area of the mercury mass is affected by the geometrical condition and takes a value between

$$\pi r_1^2 = 1.075 \times 10^{-3} \text{ m}^2 \text{ and } \pi r_2^2 = 1.37 \times 10^{-3} \text{ m}^2$$

corresponding to the magnitude of the clearance.

It is beyond the present attempt to solve this boundary value problem quite rigorously. However, it is not difficult to solve the problem, if the temperature distribution at  $x = \Delta x$  and  $x = 0$  can be assumed reasonably instead of the boundary condition (10). The writers assumed the temperature distribution as follows:

$$x = \Delta x \quad t = f_1(r) \quad (12)$$

where  $f_1(r) = t_0$  ( $0 < r < r_1$ )

$$= t_0 - Ct_0 [1 - (2/\pi) \sin^{-1} r_1/r]^*, \quad (r_1 < r < r_2)$$

$$x = 0 \quad t = f_2(r) \quad (13)$$

where  $f_2(r) = 0$  ( $0 < r < r_1$ )

$$= Ct_0 [1 - (2/\pi) \sin^{-1} r_1/r], \quad (r_1 < r < r_2)$$

A correction factor  $C$  in the above equations should be determined so as to satisfy the following equation:

$$Q = Q' \quad (14)$$

where  $Q = \int_0^{r_1} 2\pi kr (\partial t / \partial x)_{x=0} dr \quad (15)$

$$Q' = \int_0^{r_1} 2\pi kr (\partial t / \partial x)_{x=x} dr \quad (16)$$

The basic differential equation for the steady-state heat conduction in a cylinder is

$$\partial^2 t / \partial x^2 + (1/r) \partial t / \partial r + \partial^2 t / \partial r^2 = 0 \quad (17)$$

The boundary value problem denoted by equations (17), (9), (11), (12) and (13) can be separated into two somewhat simpler boundary-value problems whose solutions can be superposed to yield the solution of the original problem. Consider the following two boundary-value problems:

\* When a circular region ( $r \leq r_1$ ) of the surface of a semi-infinite solid is kept at a constant temperature  $t_0$  and the other region is insulated, the surface temperature distribution is given as  $t_0 (2/\pi) \sin^{-1} r_1/r$ .

$$\left. \begin{aligned} \partial^2 t_1 / \partial x^2 + (1/r) \partial t_1 / \partial r + \partial^2 t_1 / \partial r^2 &= 0 \\ t_1 &= f_1(r) \quad (\text{at } x = \Delta x) \\ t_1 &= 0 \quad (\text{at } x = 0) \\ \partial t_1 / \partial r &= 0 \quad (r = r_2) \end{aligned} \right\} (18)$$

$$\left. \begin{aligned} \partial^2 t_2 / \partial x^2 + (1/r) \partial t_2 / \partial r + \partial^2 t_2 / \partial r^2 &= 0 \\ t_2 &= 0 \quad (\text{at } x = \Delta x) \\ t_2 &= f_2(r) \quad (\text{at } x = 0) \\ \partial t_2 / \partial r &= 0 \quad (r = r_2) \end{aligned} \right\} (19)$$

The analytical solutions of the two problems defined by equations (18) and (19) respectively, have already been solved and are described in standard text-books of heat conduction.†

$$t_1 = \frac{2}{r_2^2} \sum_{n=0}^{\infty} \frac{J_0(\lambda_n r/r_2) \sinh(\lambda_n x/r_2)}{[J_0(\lambda_n)]^2 \sinh(\lambda_n \Delta x/r_2)} \int_0^{r_1} \rho f_1(\rho) J_0\left(\frac{\lambda_n \rho}{r_2}\right) d\rho \quad (20)$$

$$t_2 = \frac{2}{r_2^2} \sum_{n=0}^{\infty} \frac{J_0(\lambda_n r/r_2) \sinh[\lambda_n(\Delta x - x)/r_2]}{[J_0(\lambda_n)]^2 \sinh(\lambda_n \Delta x/r_2)} \int_0^{r_1} \rho f_2(\rho) J_0\left(\frac{\lambda_n \rho}{r_2}\right) d\rho \quad (21)$$

where  $\lambda_n$  is the  $n$ th root of  $J_1(\lambda_n) = 0$ .

Substituting  $f_1(r)$  and  $f_2(r)$  defined by equations (12) and (13) into equations (20) and (21), the solution of the original boundary value problem is obtained as follows:

$$\left. \begin{aligned} t &= t_1 + t_2 \\ &= (t_0 x/\Delta x) + Ct_0 \frac{\Delta x - 2x}{\Delta x} \left( \frac{r_2^2 - r_1^2}{r_2^2} - \frac{4}{\pi r_2^2} \int_{r_1}^{r_2} \rho \sin^{-1} \frac{r_1}{\rho} d\rho \right) + \frac{2t_0 C}{r^2} \\ &\quad \sum_{n=1}^{\infty} \frac{J_0 \frac{\lambda_n r}{r_2} \left( \sinh \frac{\lambda_n x}{r_2} - \sinh \frac{\lambda_n(\Delta x - x)}{r_2} \right)}{J_0(\lambda_n)^2 \sinh \lambda_n \Delta x/r_2} \\ &\quad \times \left[ \frac{r_1 r_2}{\lambda_n} J_1\left(\lambda_n \frac{r_1}{r_2}\right) + \int_{r_1}^{r_2} \left(\frac{2}{\pi}\right) \rho \sin^{-1} \frac{r_1}{\rho} J_0\left(\frac{\lambda_n \rho}{r_2}\right) d\rho \right] \end{aligned} \right\} (22)$$

From equation (14), (15), (16) and (22), one obtains

† For example, H. S. Carslaw and J. C. Jaeger, *Conduction of Heat in Solids* p. 188. Clarendon Press, Oxford (1950).

$$\begin{aligned}
 Q &= \int_0^{r_1} 2\pi kr \left( \frac{\partial t}{\partial x} \right)_{x=0} dr \\
 &= \frac{\pi k t_0 r_1^2}{\Delta x} \left\{ 1 - 2C \left( \frac{r_2^2 - r_1^2}{r_2^2} - \frac{4}{\pi r_2^2} \int_{r_1}^{r_2} \rho \sin^{-1} \frac{r_1}{\rho} d\rho \right) + \frac{4\Delta x C}{r_1 r_2^2} \times \right. \\
 &\times \sum_{n=1}^{\infty} \frac{J_1(\lambda_n r_1/r_2) [1 + \cosh(\lambda_n \Delta x/r_2)]}{[J_0(\lambda_n)]^2 \sinh(\lambda_n \Delta x/r_2)} \times \\
 &\times \left[ \frac{r_1 r_2}{\lambda_n} J_1 \left( \frac{\lambda_n r_1}{r_2} \right) + \left( \frac{2}{\pi} \right) \int_{r_1}^{r_2} \rho \sin^{-1} \frac{r_1}{\rho} J_0 \left( \frac{\lambda_n \rho}{r_2} \right) d\rho \right] \left. \right\} \quad (23)
 \end{aligned}$$

$$Q' = \frac{\pi k r_2^2 t_0}{\Delta x} \left[ 1 - 2C \left( \frac{r_2^2 - r_1^2}{r_2^2} - \frac{4}{\pi r_2^2} \int_{r_1}^{r_2} \rho \sin^{-1} \frac{r_1}{\rho} d\rho \right) \right] \quad (24)$$

From equations (14), (23) and (24), the value of C can be determined. Let

$$Q = K \frac{\pi k r_1^2}{\Delta x} t_0 \quad (25)$$

Thus, the values of K in equation (25) are computed for  $\Delta x = 0.0035, 0.0040$  and  $0.0045$  m when  $r_1 = 1.85$  and  $r_2 = 2.10$ . The results are

shown in Table 1 in which the values of C are also shown.

Table 1. The values of K in equation (25), and of C in equations (12) and (13) which satisfy equation (14)

$\Delta x$ (m)	K	C
0	1.000	—
0.0035	1.086	1.621
0.0040	1.099	1.535
0.0045	1.109	1.457

Since the assumptions of the temperature distribution of equations (12) and (13) are not reasonable when the value of  $\Delta x$  is too small, the calculations were limited to  $\Delta x \geq 0.0035$ . However, from inspection of the variation of K listed in Table 1, it may be assumed that the values of K between  $\Delta x = 0$  and  $\Delta x = 0.0035$  m can be correlated approximately by a linear function of  $\Delta x$  as follows:

$$K = 1 + 24.8 \Delta x \quad (26)$$

Consequently,

$$A_{Hg} = K \pi r_1^2 = (1 + 24.8 \Delta x) (\pi r_1^2) \quad (27)$$

where K,  $\Delta x$  and  $A_{Hg}$  have dimensions (-), (m) and ( $m^2$ ), respectively.